

G. BELL.  
 Driving Attachment for Sewing-Machine.  
 No. 204,943.      Patented June 18, 1878.

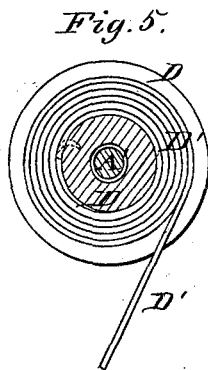
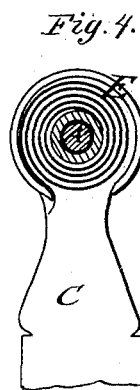
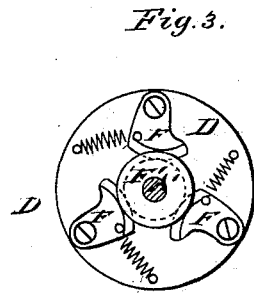
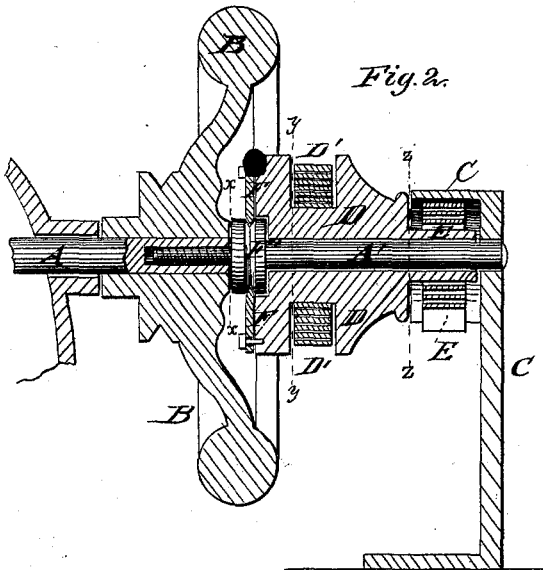
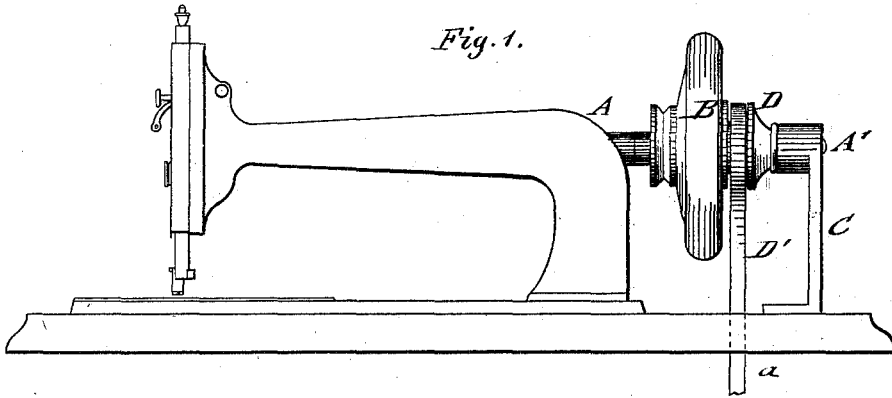

WITNESSES:  
*Henry N. Miller*  
*C. Sedgwick*

INVENTOR:  
*G. Bell*  
 BY *Munn & Co.*  
 ATTORNEYS.

# UNITED STATES PATENT OFFICE.

GAYLORD BELL, OF CHEYENNE, WYOMING TERRITORY.

## IMPROVEMENT IN DRIVING ATTACHMENTS FOR SEWING-MACHINES.

Specification forming part of Letters Patent No. **204,943**, dated June 18, 1878; application filed March 22, 1878.

*To all whom it may concern:*

Be it known that I, GAYLORD BELL, of Cheyenne, in the county of Laramie, Wyoming Territory, have invented a new and Improved Driving Attachment for Sewing-Machines, of which the following is a specification:

In the accompanying drawing, Figure 1 represents a side elevation of a sewing-machine with my improved driving attachment. Fig. 2 is a vertical central section of the driving attachment on enlarged scale; Fig. 3, a side view, partly in section, on line *x x*, Fig. 2, of the eccentric-cams that clutch the extension-shaft of the driving attachment; and Figs. 4 and 5 are vertical transverse sections of the attachment, respectively on line *z z* and *y y*, Fig. 2.

Similar letters of reference indicate corresponding parts.

The object of this invention is to provide for sewing-machines, lathes, scroll-saws, and other light machinery an improved driving attachment, by which the same may be run in even and effective manner by the pressure of the foot, without dead-centers, and without any possibility of running backward so as to break the thread.

The attachment forms a cheap, neat, and portable device for the rapid and easy working of sewing and other machines.

The invention consists of a loose pulley turning on an extension of the driving-shaft of the sewing or other machine, the pulley being revolved in one direction thereon by a strap wound around the pulley and attached to the same and to a foot-treadle, and in opposite direction by a strong spiral spring attached to the pulley and to a fixed standard.

The forward motion of the pulley is transmitted to the driving-shaft by means of pivoted and spring-acted eccentric-cams, that bite into an annularly-grooved collar of the extension-shaft, but release the same when turned in opposite direction by the spiral spring.

Referring to the drawing, A represents the driving-shaft of a sewing-machine, lathe, or other light machinery, which is provided in the customary manner with a fly-wheel, B, of suitable size. Into the end of the driving-shaft

A is screwed or otherwise attached an extension-shaft, A', whose outer end is supported in a bearing of a vertical standard, C, attached to the table of the sewing or other machine. On the extension-shaft A' is placed a loose pulley, D, that is provided at its middle portion with an annular groove, in which is placed a leather strap, D', that is attached by its inner end to the pulley, then wound around the same, and extended through a guide-perforation of the table to a hinged treadle, that is acted upon by the foot or in any other manner.

The belt is provided with a suitable stop-pin or other device, *a*, that prevents the passing up of the belt beyond a certain point.

To the outer sleeve-shaped end of the pulley D is attached a clock-spring, E, that is coiled around the sleeve in opposite direction to the strap D', and acts on the pulley in similar manner as the hair-spring in a watch. The outer end of the spring E is attached to the inclosing-casing C' of the standard C, the spring serving to turn the pulley in one direction, while the strap and treadle arrangement turns it in opposite direction thereto.

To the inner end of the pulley D are attached a number of pivoted and spring-acted cams, F, that are case-hardened, and made pointed at their eccentric edges, so as to bite into a correspondingly-grooved collar, F', of the extension-shaft when the shaft is turned by the strap, but release the shaft as soon as the pressure on the treadle is relaxed and the clock-spring thrown into action for turning the pulley in opposite direction.

The succession of strokes of the treadle causes, by means of the pulley and cams, the revolving of the driving-shaft in one direction, while the spring produces the return motion of the pulley and rewinding of the treadle-operated strap, the fly-wheel keeping up the continuous motion of the driving-shaft in one direction.

In this manner a simple, easily-operated, and very effective driving attachment for sewing-machines is obtained that may be arranged on any sewing-machine, and which takes up little space, and is cheaper than the customary supporting-frames and treadle arrangements.

Having thus described my invention, I claim as new and desire to secure by Letters Patent— winding in opposite directions, as and for the purpose specified.

The combination, with the shaft A A', having collar F', of the loose pulley D, provided with pivoted spring-cams F, a treadle-strap, D', and a coiled spring, E, said strap and spring

GAYLORD BELL.

Witnesses:

GEO. B. STIMPSON,  
E. H. INGALLS.